

Distans för konsol

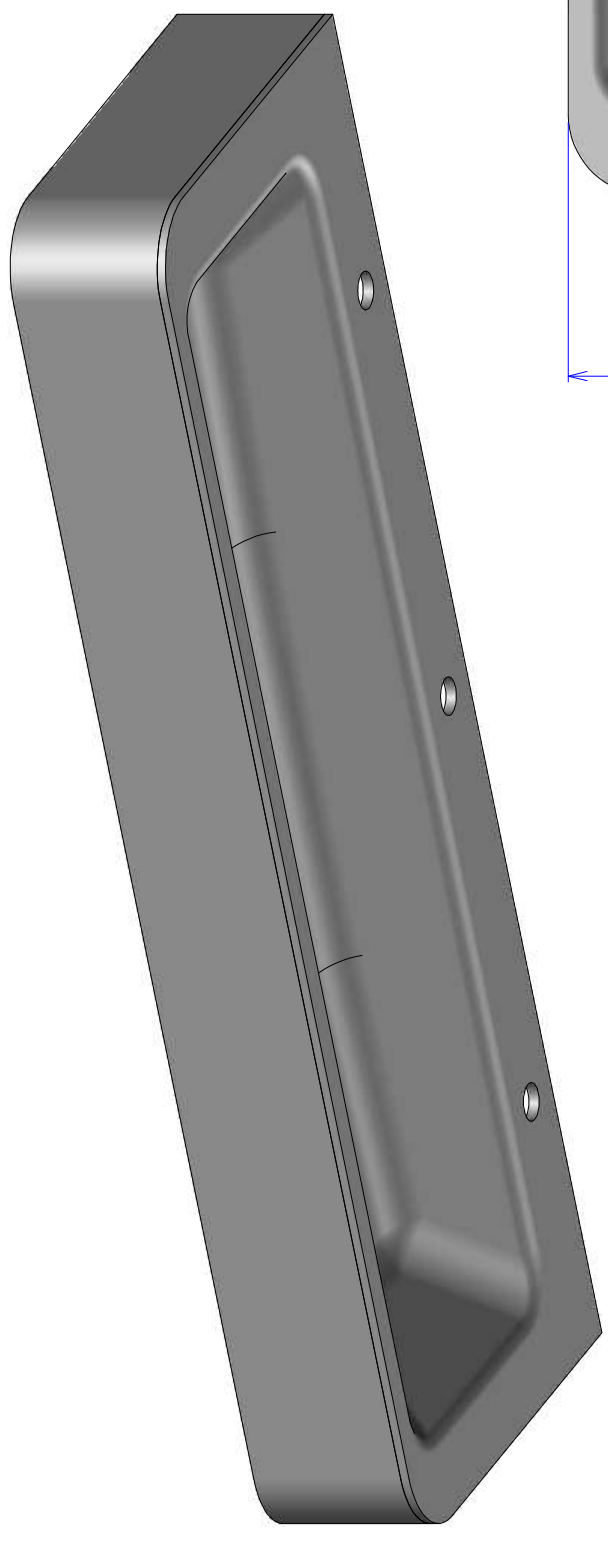
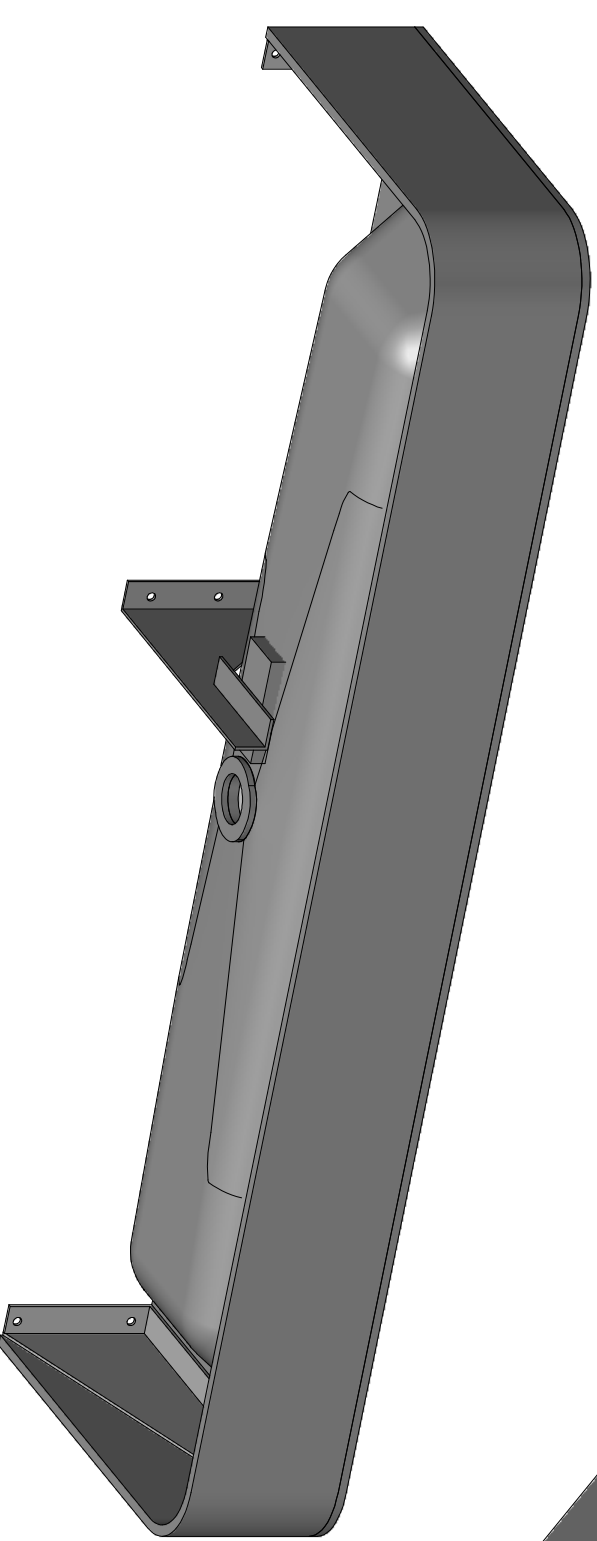

-	1	1	Topp	Glacier White	-	1300.0	430.0	135.0	1300.0	430.0	135.0
-	1	1	Konsol för mod 02	Plåt 3,0 mm	-	275.0	166.5	30.0	275.0	166.5	30.0
-	1	1	H Konsol 138x380	plåt 3,0 mm	-	380.0	138.0	30.0	380.0	138.0	30.0
-	1	1	Distans	Glacier White	-	75.3	77.9	6.0	75.3	77.9	6.0
-	1	1	Distans för konsol	GW	-	100.0	50.0	14.0	100.0	50.0	14.0
-	1	1	V Konsol 138x380	plåt 3,0 mm	-	380.0	138.0	30.0	380.0	138.0	30.0

Ritad	Jonas W	Godk.	JonasW	Skala	A3 1:10	Projekt	Projekt	Blad	1/1	Datum	30/03/2020
<p>NOAS S W E D E N Fabriksgratan 2, 543 50 Tibro 0504-495100, www.noassweden.se</p>											
<p>TR1300GW-430-3</p>											
<p>Där ej annat anges Rev.</p>											
<p>ISO 2768-m</p>											
<p>Ritn.nr</p>											