

A - A

Distans för konsol

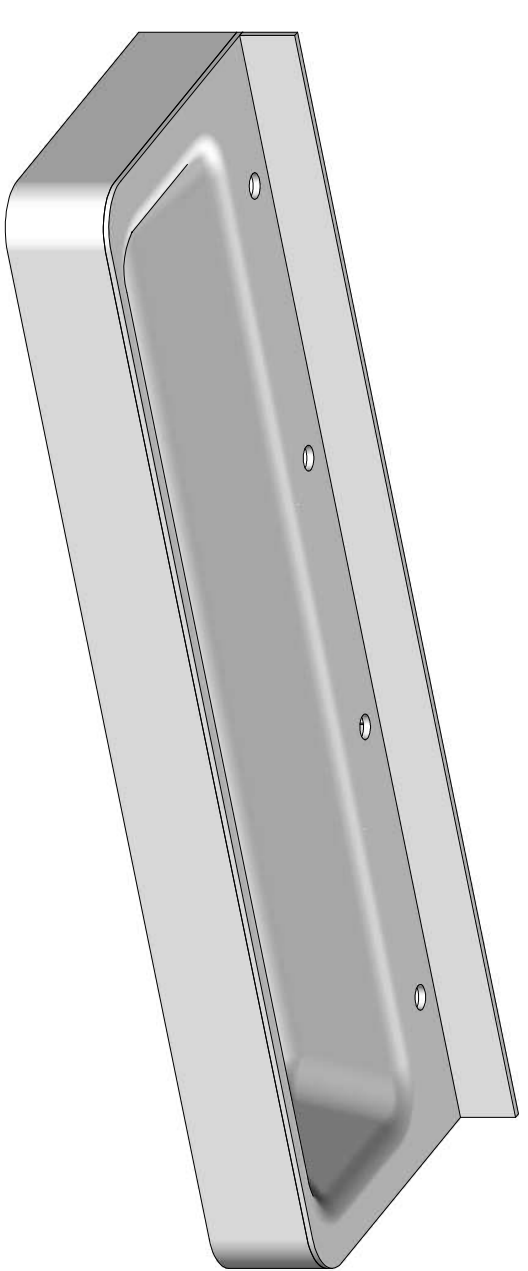
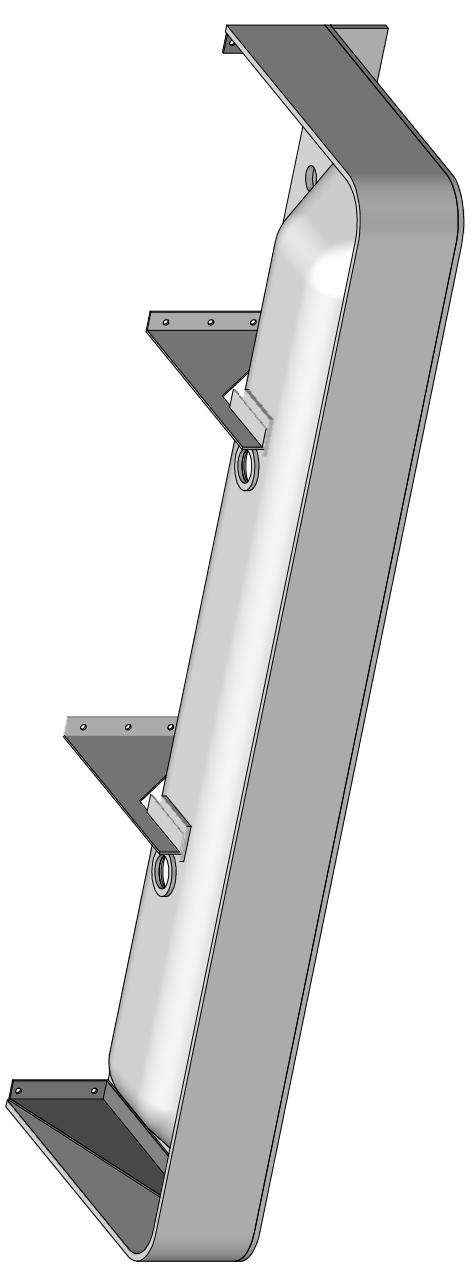
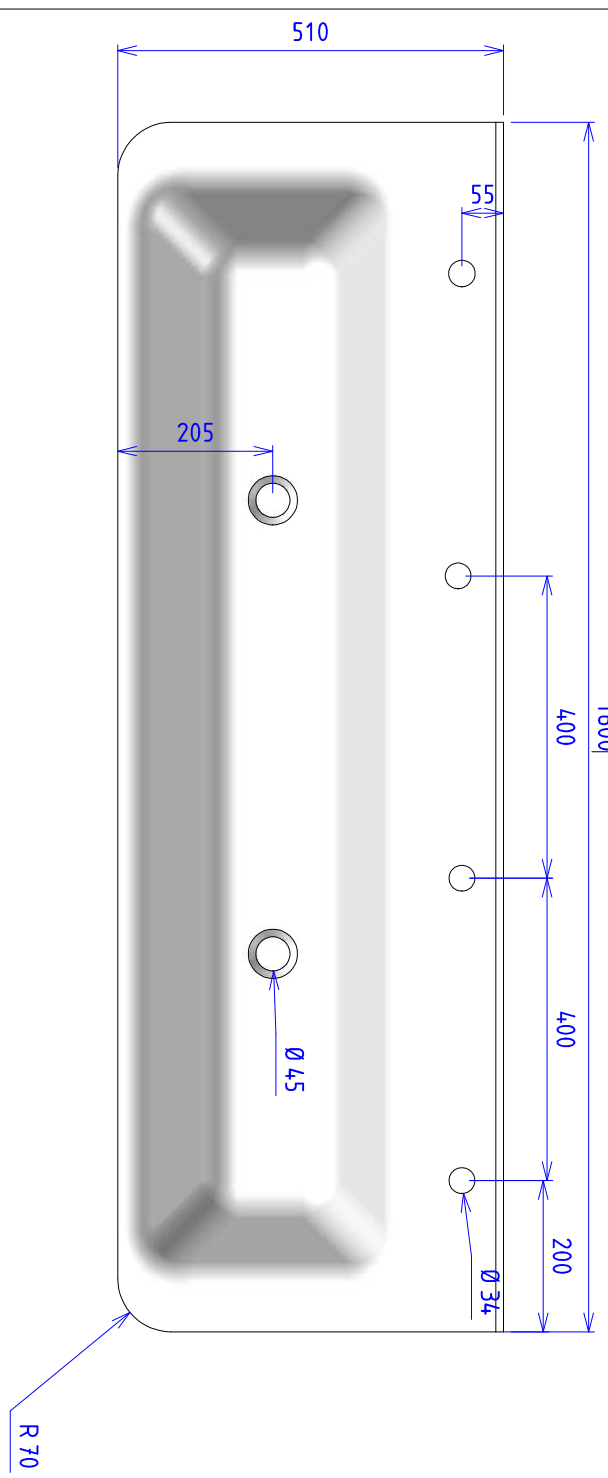

Art.nr.	Ant.	Benämning	Skala	Projekt	Material	Kommentar	Kap L	Kap B	Kap Tj	L	B	Tj
1	1	Stänkskydd			plåt 3,0 mm		1600,0	510,0	140,0	1600,0	510,0	140,0
-	1	Konsol spec mitt			plåt 3,0 mm		1600,0	80,0	10,0	1600,0	80,0	10,0
-	1	Konsol Spec mitt			plåt 3,0 mm		348,3	166,5	30,0	348,3	166,5	30,0
-	1	H Konsol 138x380			plåt 3,0 mm		348,3	166,5	30,0	348,3	166,5	30,0
-	1	V Konsol 138x380			plåt 3,0 mm		380,0	138,0	30,0	380,0	138,0	30,0
-	1	Front			GW		1600,0	510,0	142,0	1600,0	510,0	142,0
-	1	Distans för konsol			GW		653,1	90,5	6,0	653,1	90,5	6,0
-	2	Distans			GW		65,0	65,0	6,0	65,0	65,0	6,0
-	1	V Konsol 138x380			plåt 3,0 mm		380,0	138,0	30,0	380,0	138,0	30,0

Ritad	Jonas W	Godk.	JonasW	Skala	A3 1:10	Projekt	Projekt
Art.nr.	JonasW	Benämning	A3 1:10	Skala	Projekt	Projekt	
<p>NOAS S W E D E N Fabriksgratan 2, 543 50 Tibro 0504-495100, www.noassweden.se</p>							
<p>Tvättänna 1600GW-510-4-B</p>							
<p>Där ej annat anges Rev. 1/1 30/03/2020</p>							
<p>ISO 2768-m</p>							
<p>Ritn.nr</p>							