

A - A

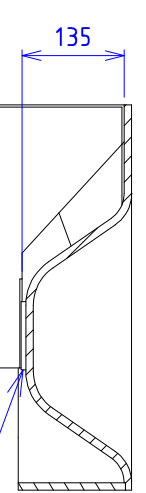

Distans för konsol

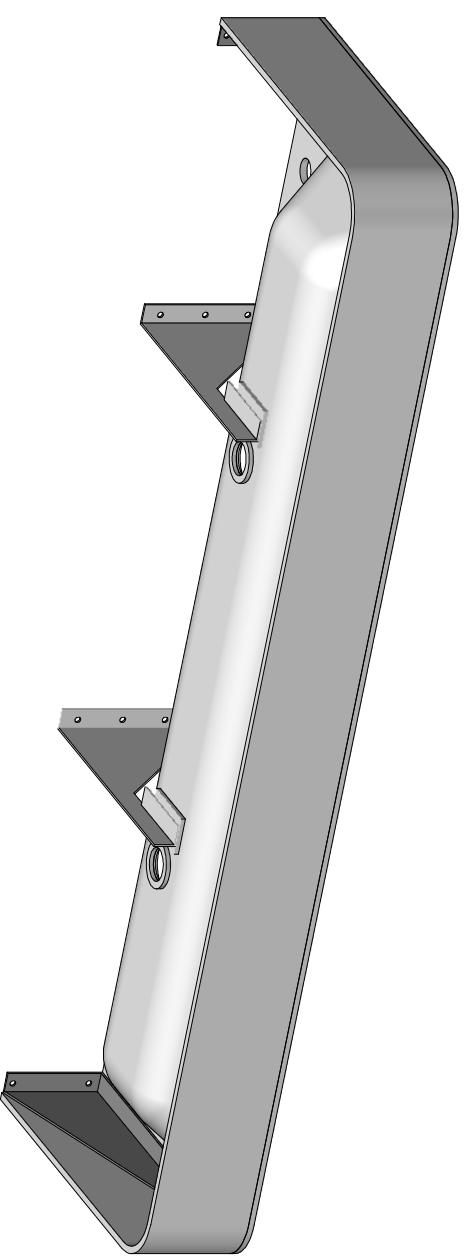
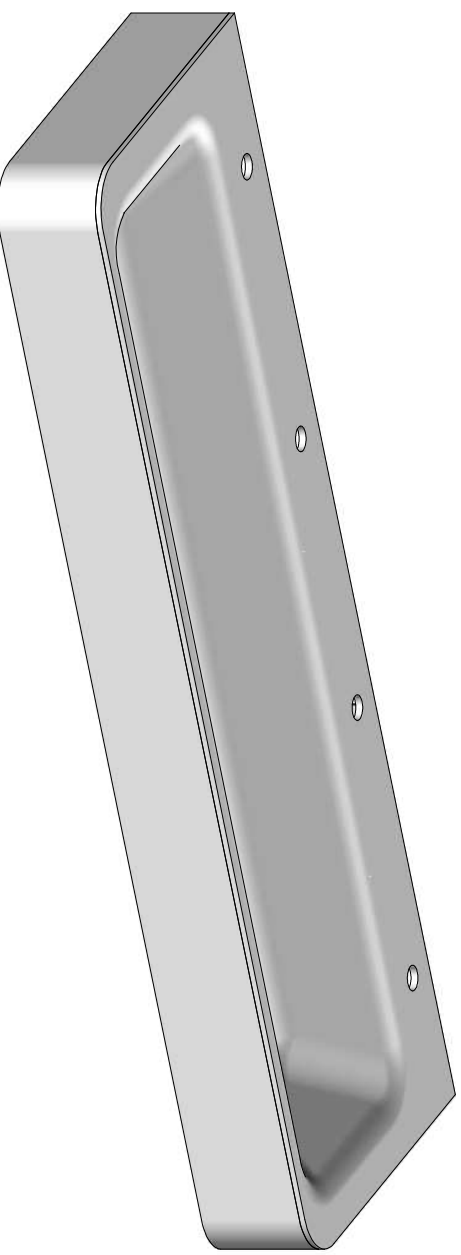
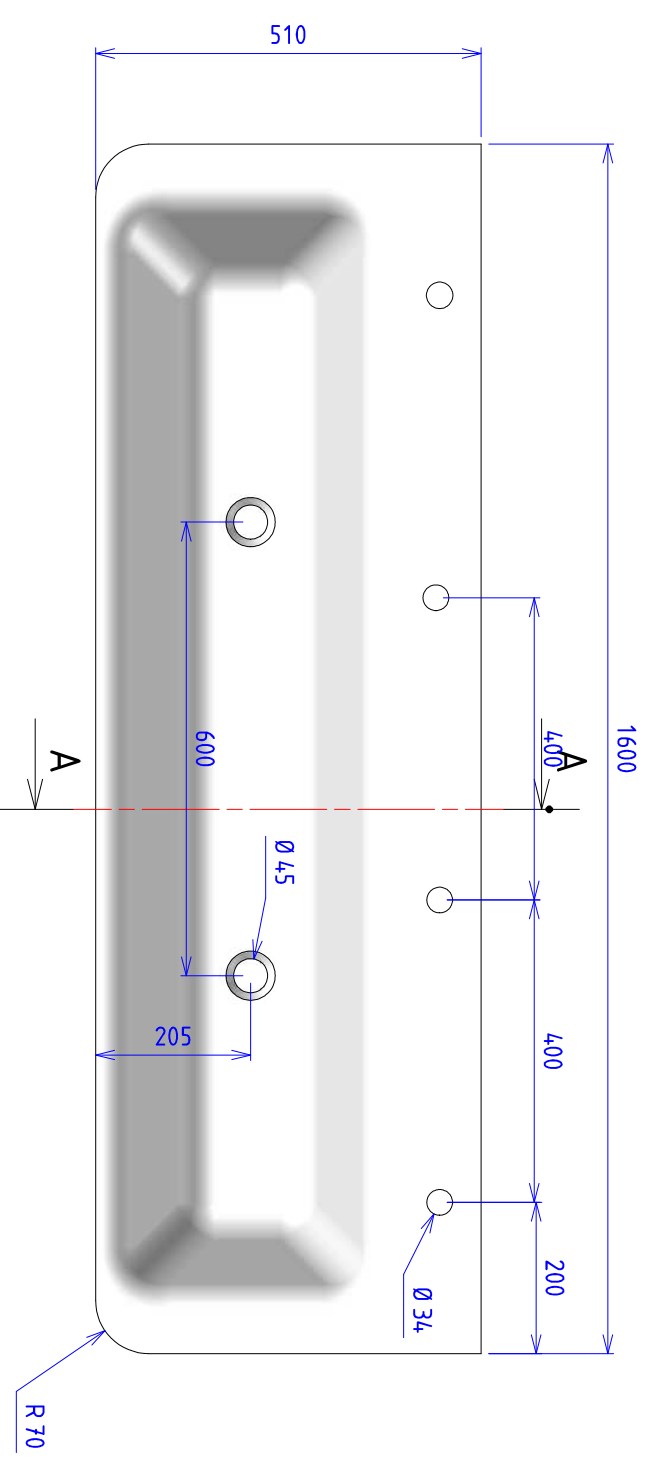

Art.nr.	Ant.	Benämning	Skala	Projekt	Material	Kommentar	Kap L	Kap B	Kap Tj	L	B	Tj
-	1	Topp			##%Jonas %Corian GW	-	1600,0	510,0	140,0	1600,0	510,0	140,0
-	1	Konsol spec mitt			Plåt 3,0 mm	-	348,3	166,5	30,0	348,3	166,5	30,0
-	1	Konsol Spec mitt			Plåt 3,0 mm	-	348,3	166,5	30,0	348,3	166,5	30,0
-	1	H Konsol 138x380			plåt 3,0 mm	-	380,0	138,0	30,0	380,0	138,0	30,0
-	1	Front			GW	-	1600,0	510,0	142,0	1600,0	510,0	142,0
-	1	Distans för konsol			GW	-	653,1	90,5	6,0	653,1	90,5	6,0
-	2	Distans			GW	-	65,0	65,0	6,0	65,0	65,0	6,0
-	1	V Konsol 138x380			plåt 3,0 mm	-	380,0	138,0	30,0	380,0	138,0	30,0

Ritad	Godk.	Skala	Projekt	Datum
Jonas W	JonasW	A3 1:10	Projekt	1/1 30/03/2020

NOAS

S W E D E N
Fabriksgratan 2, 543 50 Tibro
0504-495100, www.noassweden.se

Tvättänna 1600GW-510-4

Där ej annat anges
ISO 2768-m Rev.

Ritn.nr